

# PREPARATION du CONTROLE

NOM ..... DATE .....

...../5

Fiche 07A

Arrondi au 10e  
Résultats aux stylo noir ou bleu

ENONCE 1: Calculer la longueur des traverses meneaux des châssis ci-dessous :

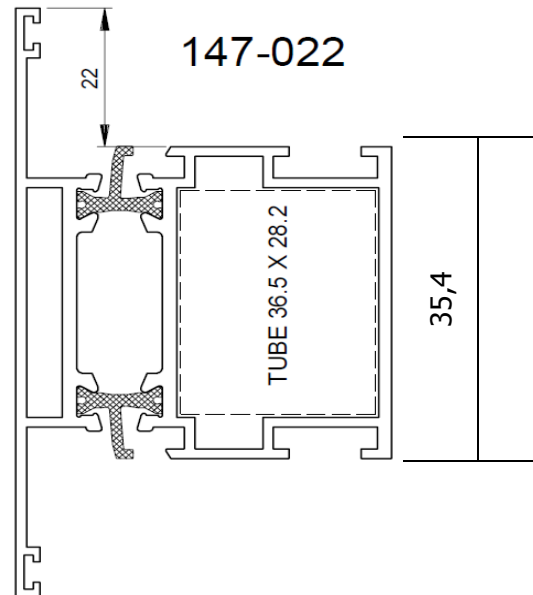
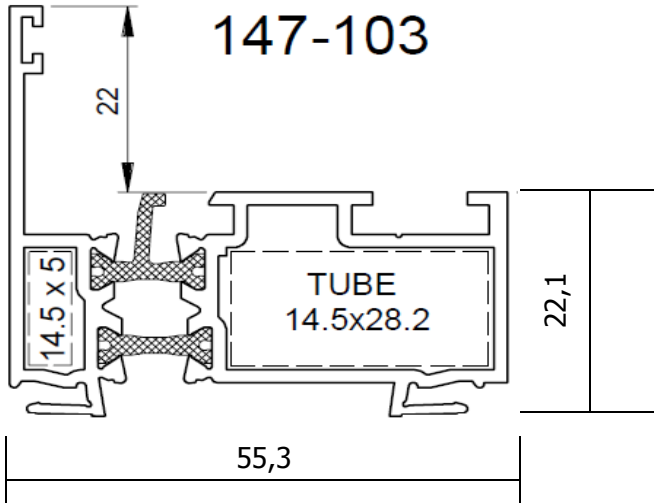
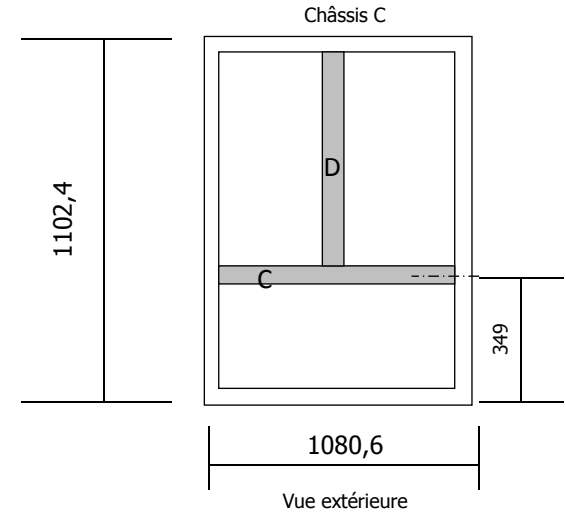
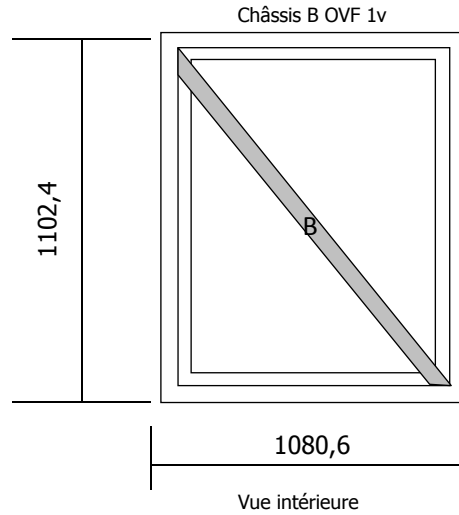
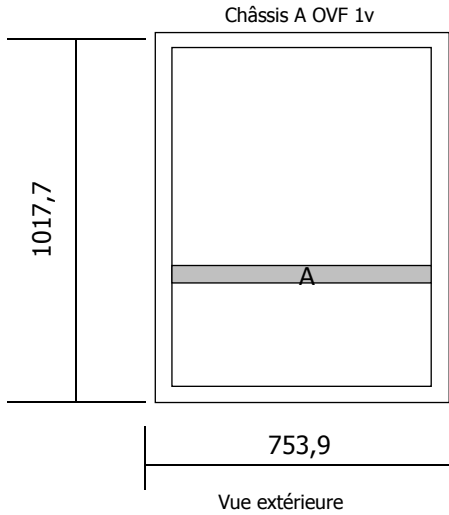

A =	..... /5pts
B =	..... /5pts
C =	..... /5pts
D =	..... /5pts

