

PREPARATION du CONTROLE

NOM DATE

...../5

Fiche 07A

Arrondi au 10e
Résultats aux stylo noir ou bleu

ENONCE 1: Calculer la longueur des traverses meneaux des châssis ci-dessous :

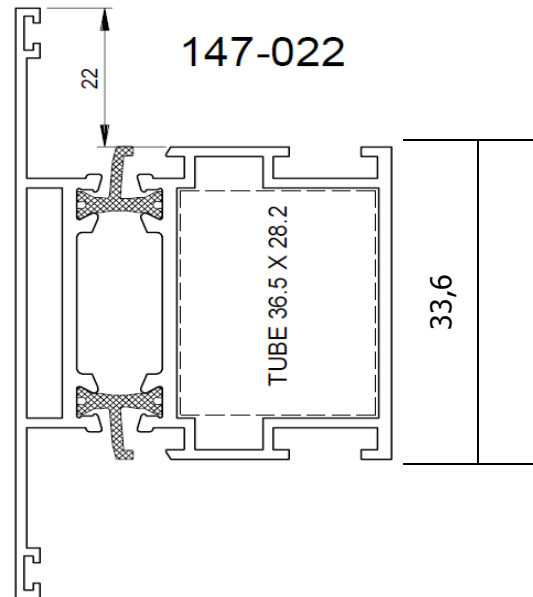
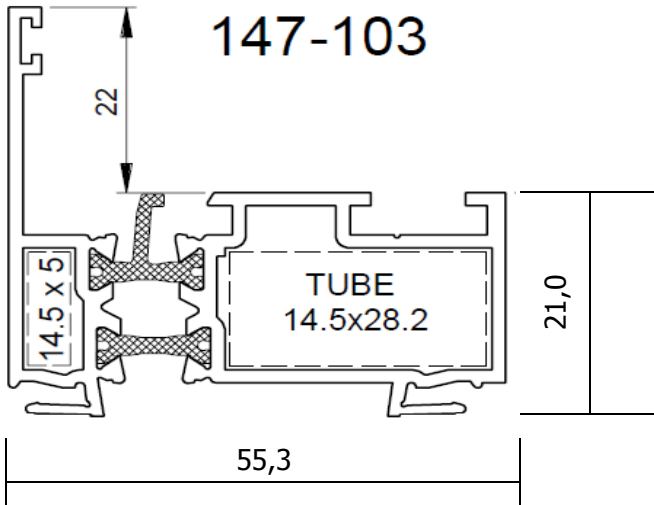
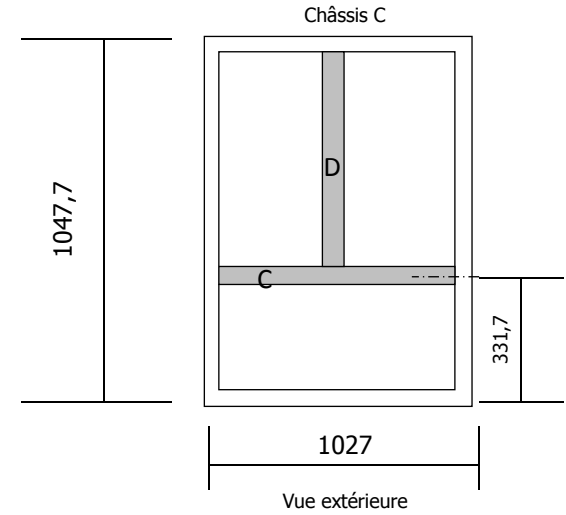
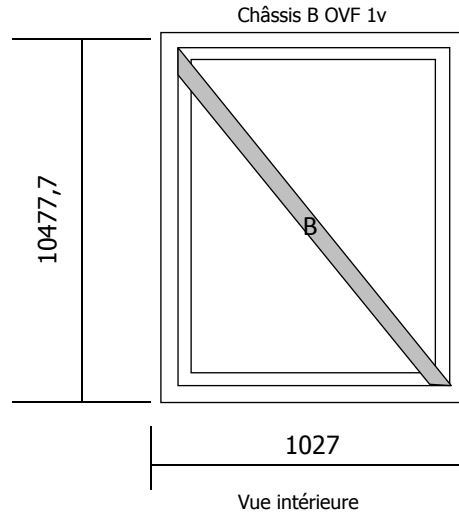
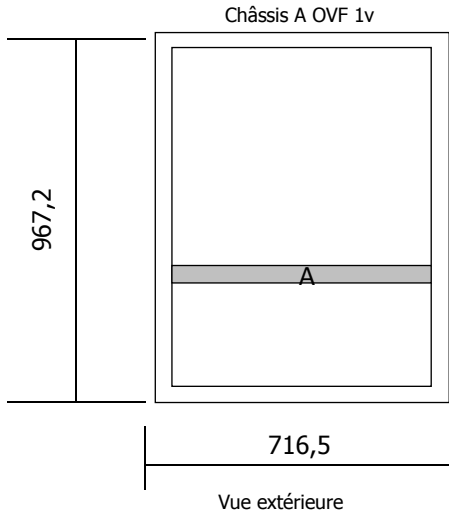

A =	674,5 /1pt
B =	10482,1 /1pt
C =	985,0 /1pt
D =	678,2 /2pts

